

203-011

DGUV Information 203-011



Hand-operated cutting devices

komm**mit****mensch** is the national campaign of the German Social Accident Insurance (DGUV). Its purpose is to support companies and educational institutions in developing a culture of prevention in which all action is underpinned by safety and health. Further information at www.kommmitmensch.de

Legal information

Published by:

Deutsche Gesetzliche
Unfallversicherung e.V. (DGUV)

Glinkastraße 40
10117 Berlin
Germany
Telephone: +49 30 13001-0 (switchboard)
E-Mail: info@dguv.de
Internet: www.dguv.de

Subcommittee Printing and Paper converting of Expert Committee Energy Textile
Electrical Media Products sectors of DGUV

Date of issue: September 2021

The present DGUV Information is the translation of the German edition
(issued February 2021). No liability is accepted for translation errors.

The following significant changes have been made compared to the last version of
this DGUV information from 2011:

- Images have been added and graphics have been revised.
- The sections “Scope of application”, “General”, “Cardboard shear cutters, manual guillotine trimmers”, “Stack paper cutters”, “Paper dispensers”, “Operating instructions” have been technically specified.
- The section “Operation of hand-operated cutting devices” was added.

DGUV Information 203-011

Obtainable from: your accident insurance institution, or at
www.dguv.de/publikationen Webcode: p203011

Figures:

Front Cover: © Valentin Kazda – BG ETEM

Page 6: © JRJfin/stock.adobe.com

Fig. 9, 12: © DGUV/Atelier Hauer+Dörfler GmbH

Fig. 1–8, 10–11, 13–14: © DGUV/H.ZWEI.S Werbeagentur GmbH

Hand-operated cutting devices

Table of contents

	page
Foreword	5
Scope of application	6
1 Definitions	7
Manual guillotine trimmers	7
Rotary cutters	7
Stack paper cutters	8
Paper dispensers	8
Cardboard shear cutters	8
2 Information for the design of hand-operated cutting devices	9
General	9
Cardboard shear cutters, manual guillotine trimmers	9
Stack paper cutter	11
Rotary cutters	12
Paper dispensers	13
Operating instructions	13
3 Operation of hand-operated cutting devices	14
Information for employees	14
Inspection and maintenance	14
Annex	15

Foreword

DGUV Information publications are first and foremost intended to support employers in the implementation of their obligations under state occupational health and safety regulations, accident prevention regulations and, where applicable, DGUV rules, and to show ways to prevent occupational accidents, occupational diseases and work-related health problems.

Employers complying with the recommendations given in these DGUV Information publications, especially with the exemplary potential solutions, can assume to achieve the protection targets required by the accident prevention regulations as well as other protection targets of the accident insurance institutions. Other solutions are possible if safety and health protection are guaranteed in the same way. If technical rules have been established by the committees set up in order to specify state occupational health and safety regulations, these are to be observed as a matter of priority.

The technical solutions given in this DGUV Information do not exclude other solutions which are at least equally safe and which have also been specified in technical rules of other member states of the European Union or other contracting states to the Agreement on the European Economic Area.

The following design rules in this DGUV Information are presented in relation to the equipment.

Scope of application

The design rules were developed for new hand-operated cutting devices intended to cut paper or similar materials and serve to specify the Product Safety Act (ProdSG) as well as chapter 2.2 “Operation of printing and paper converting machines” of the DGUV rule 100-500 and 100-501 “Operation of technical equipment”.

With regard to the different types of hand-operated cutting devices, the design rules include on the one hand requirements for construction and equipment, which concerns the application of the Product Safety Act by the manufacturer, and on the other hand requirements concerning the operation of the equipment in the respective companies. Operators of hand-operated cutting devices must comply with the EC Work Equipment Directive 2009/104/EC, which was implemented into national law in Germany by the Ordinance on Industrial Safety and Health (BetrSichV).



1 Definitions

For the purpose of this DGUV Information, the following definitions are used:

Manual guillotine trimmers

are hand-operated cutting devices used to trim one or several single sheets. The cut is made by lowering the guillotine blade against a cutting bar.

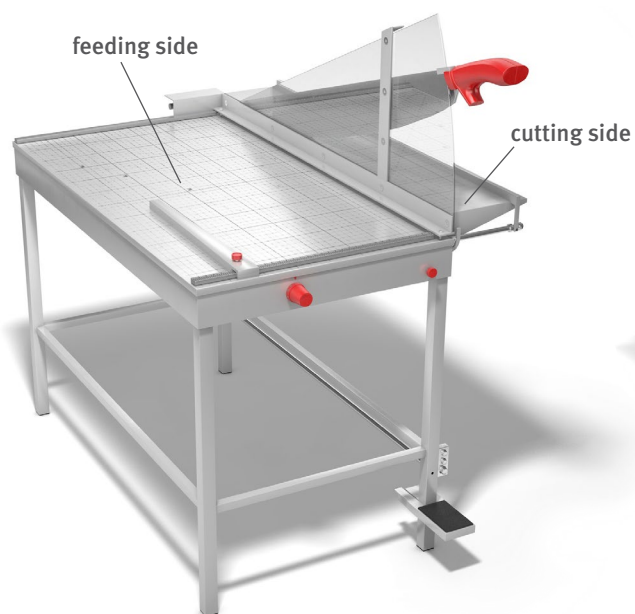

Fig.1 Manual guillotine trimmer

Rotary cutters

are hand-operated cutting devices used to trim one or several single sheets. For cutting, a circular blade is moved along a cutting bar.

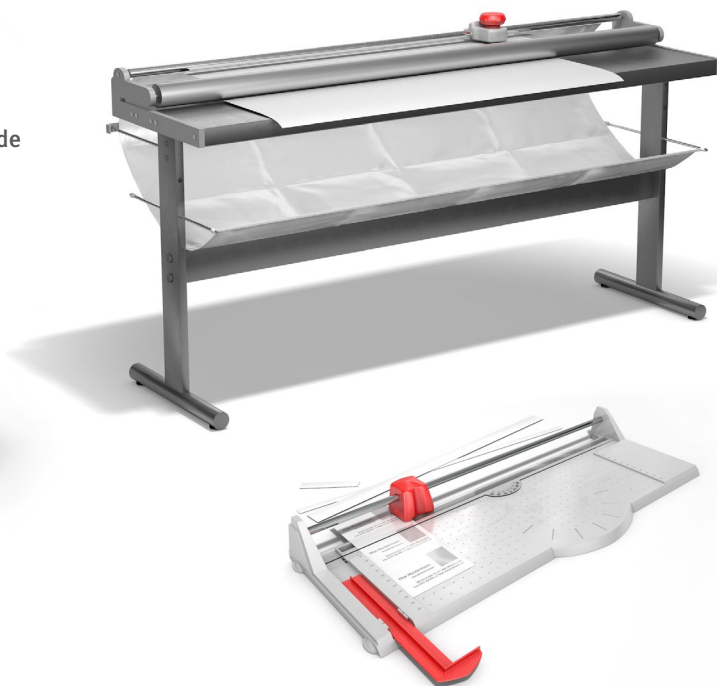

Fig.2 Rotary cutter

Stack paper cutters

are hand-operated cutting machines for cutting stacked sheets of paper or similar materials. For cutting, a lever is used to guide the blade downwards via a lever linkage.

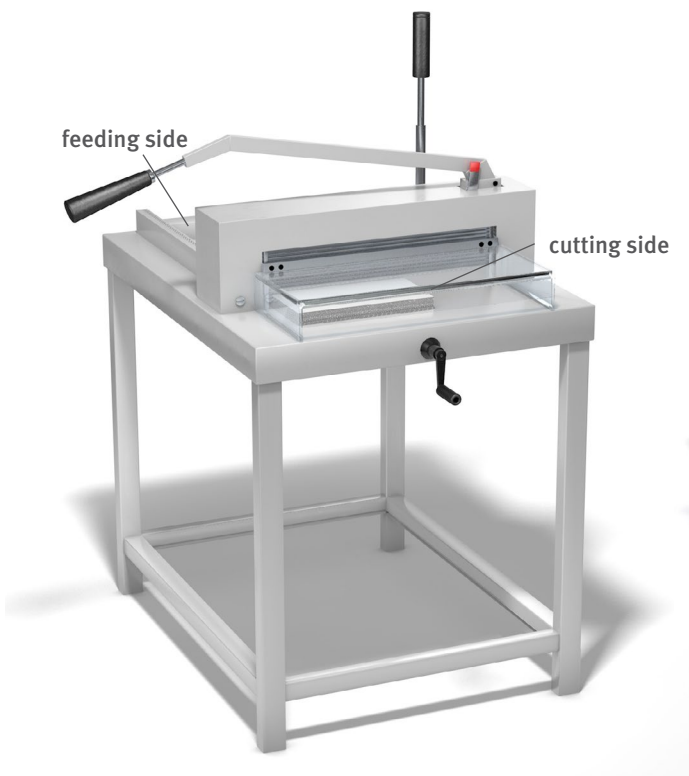

Fig. 3 Stack paper cutter

Paper dispensers

serve to pull paper or foil from a roll and to sever the material at a predetermined length. The material is torn against a cutting edge, separating the piece of paper or foil from the roll.

Cardboard shear cutters

are cutting machines for trimming one or several cardboard sheets. The cut is made by pressing a knife bar against a cutting bar.

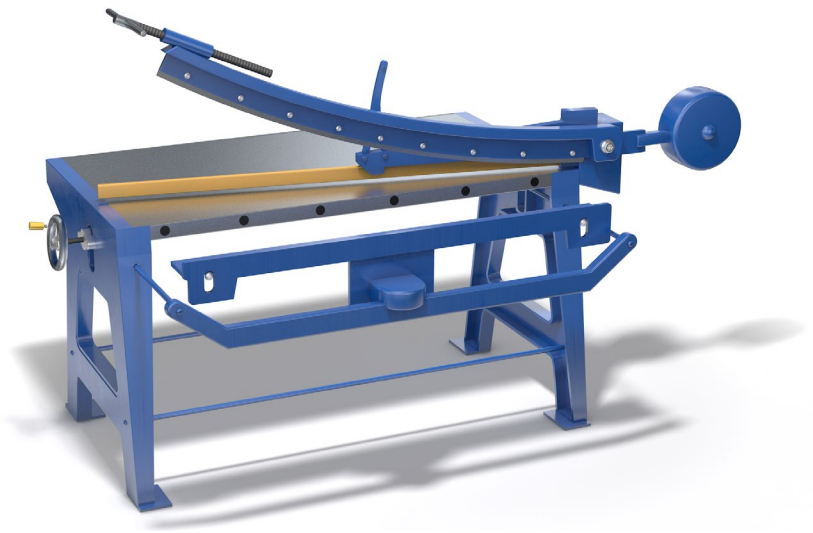

Fig. 4 Cardboard shear cutter



Fig. 5 Paper dispenser

2 Information for the design of hand-operated cutting devices

General

- Safety devices must be sufficiently strong to sustain the stresses to be expected and be so designed as to allow the cutting area to be observed.
- Surfaces and edges must be designed in such a way that they cannot cause injuries.
- Racks for holding the cutting devices and paper dispensers must be designed and installed in such a way that they can safely support the loads when used as intended. Their stability and load-bearing capacity must be adequate for the operational stresses and must be verified by the manufacturer by means of mathematical load-bearing capacity verifications for the load-bearing elements or by load tests.
- The maximum admissible loads must be indicated on the rack.
- Cutting devices must be secured against slipping. This can be achieved, for example, by providing rubber knobs on the underside of the cutting device.

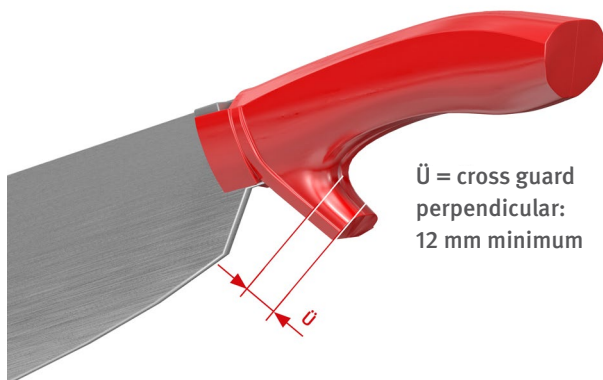

Fig. 6 Knife handle

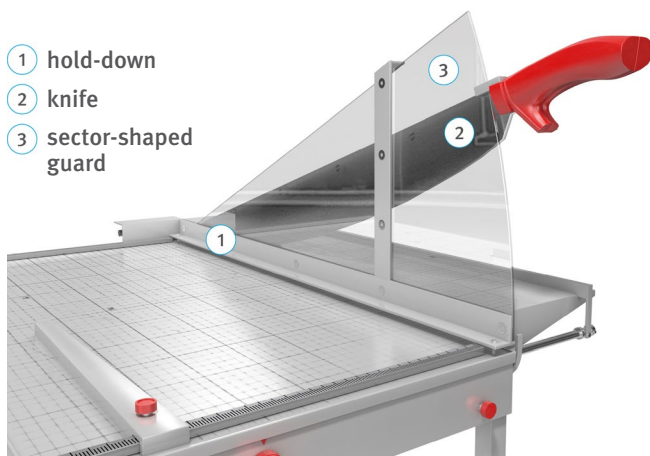

Fig. 7 Guillotine trimmer

Cardboard shear cutters, manual guillotine trimmers

- The knife must be held in its top position by positive action, for example by springs, friction or counterweight.
- Counterweights are required to be positively secured.
- Friction elements for positively holding the knife must be adjustable.
- On the bottom side, the knife handle must be provided with a cross guard perpendicular to the spine of the knife in order to prevent fingers sliding onto the blade. This guard must have a length of 12 mm minimum (see figure 6).
- Cross guards are not required where the distance between the cutting edge and the handle is at least 70 mm or where blunt knives in accordance with figure 9 are used.
- The knife edge must be secured in every position.
- The distance between the guard and the blade plane must be as small as possible. For cutting lengths up to 590 mm, the distance must not be greater than 3 mm and for cutting lengths of more than 590 mm, the distance must not be greater than 6 mm.
- The knife edge is secured, for example, by a sector-shaped guard behind the blade plane up to the hold-down (Fig. 7). The sector-shaped guard must not have any openings and no recesses on the cutting side.
- Cutters with a cutting length of more than 1.3 m can do without the sector-shaped guard if they are provided with a pressing device (hold-down) which has a height of at least 120 mm and its upper edge is at a distance of 25 mm minimum from the cutting plane (Fig. 8).

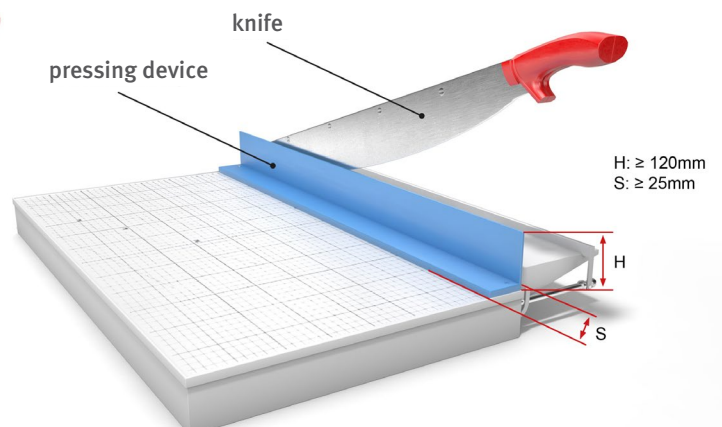

Fig. 8 Pressing device

- A safety device (e.g. a sector-shaped guard) can be omitted if the knife angle is more than 86° (blunt knife edge) and the thickness of the knife edge is at least 1.5 mm (Fig. 9).

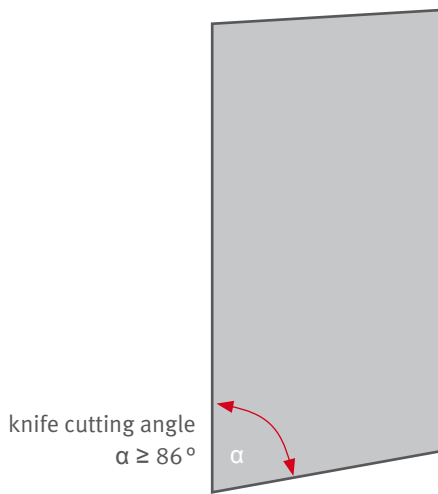

Fig. 9 Knife cutting angle more than 86°

- Access to the knife from the feeding side must be prevented. This may be achieved, for example, by means of a pressing device (hold-down) or other kinds of guards, whereby the gap between the table and the lower edge of the hold-down or guard has to be determined in compliance with the safety distance to the cutting plane as defined in EN ISO 13857.
- In the case of foot-operated or automatic pressing (the hold-down is mechanically connected with the downward movement of the knife), the stroke of the pressing device must be limited to 8 mm unless access to the pinching point is prevented by design measures.
- The knife edge must be covered in its lowest position (Fig. 10).

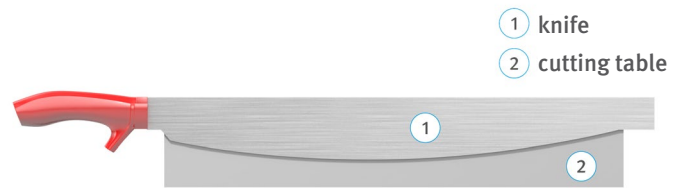

Fig. 10 Manual guillotine trimmer, cardboard shear cutter: knife in lowest position

- The front paper stop or paper tray must be secured against accidental dropping.

Stack paper cutter

- On the cutting side, a hinged tunnel-type guard is required. It must have a length of at least 110 mm, just like the table. An opening may only be present at the front. Admissible opening widths depending on the tunnel length are specified in figure 12. If possible, the hinged tunnel-type guard should prevent direct access to the blade's danger zone.

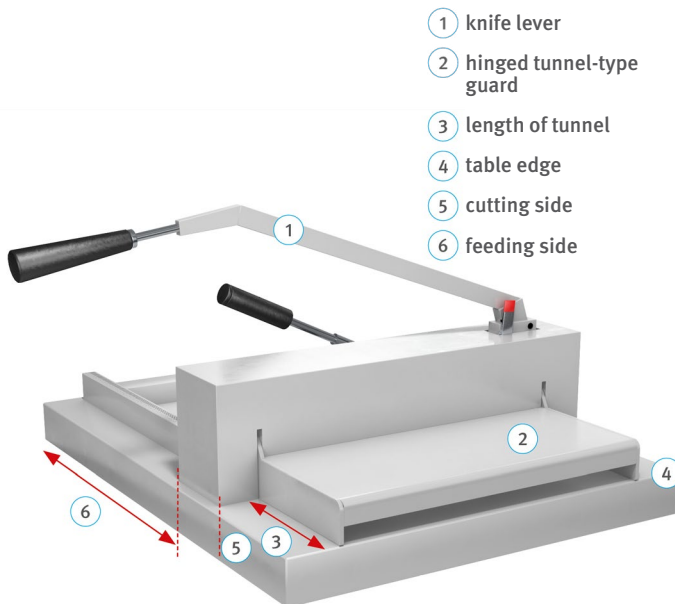

Fig. 11 Knife protection on the cutting side

- If the tunnel-type guard is open, the downward movement of the knife must be prevented. Lifting of the blade cover must be allowed only if the knife is in the top position.
- Downward movement of the knife must be possible only if the cover is in guarding position.

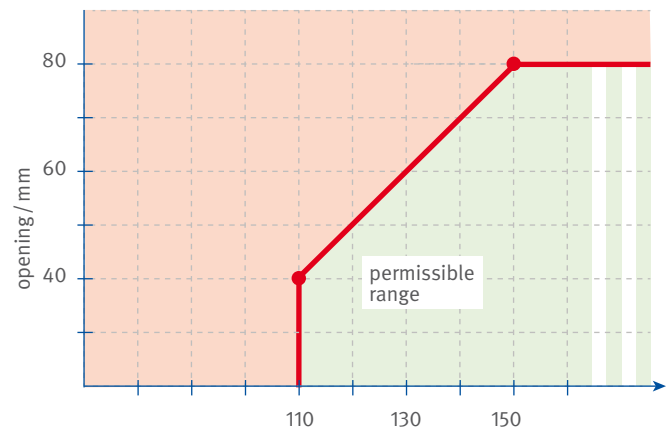

Fig. 12 Opening width in relation to the tunnel length

- Access to the knife from the top must be prevented.
- A tunnel-type guard of at least 110 mm length is required on the feeding side so that the knife cannot be reached. The possible opening widths are shown in figure 12. In case the guard is of the hinged type, the requirements specified left at paragraph “stack paper cutter” also apply.
- In the top position of the knife, the knife edge must always be covered by the hold-down.
- The lever holding the knife and the hold-down must be safely secured in the top position.
- For knife changing, adequate supporting elements with blade covers must be provided in order to make knife changing safe.
- Knife changing procedures must be described in detail in the operating instructions.

Rotary cutters

- The rotary knife must be secured against contact except for that part used in the cutting operation.
- Changing the cutter head (rotary knife) must be easy.
- The distance between the cutting table and the guard covering the rotary knife must not exceed 5 mm on the inlet and outlet side (Fig. 13, A).

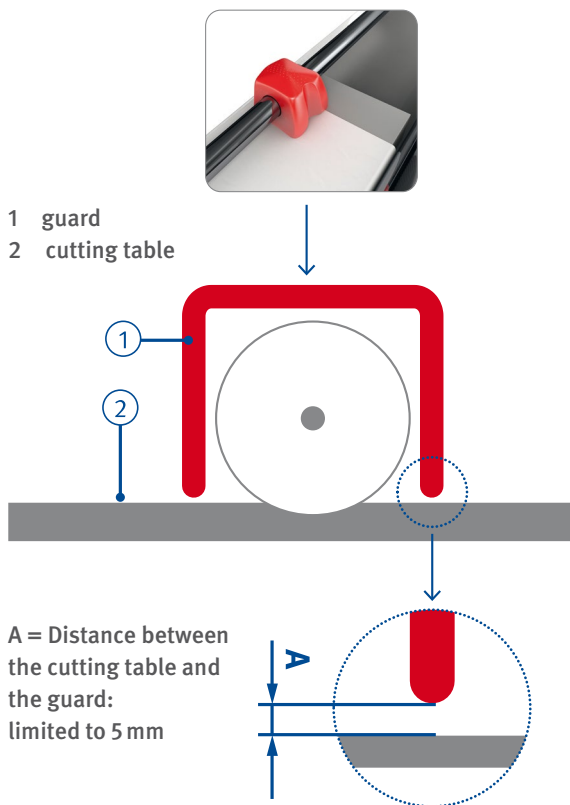

Fig. 13 Cover guarding the rotary knife

- The distance between the rotary knife and the cutting table should not exceed 2 mm (Fig. 14, B). A minimum distance is not required for blunt rotary knives (cutting angle greater than 86° , see Fig. 9).

- 1 guard
- 2 cutting table
- 3 rotary knife

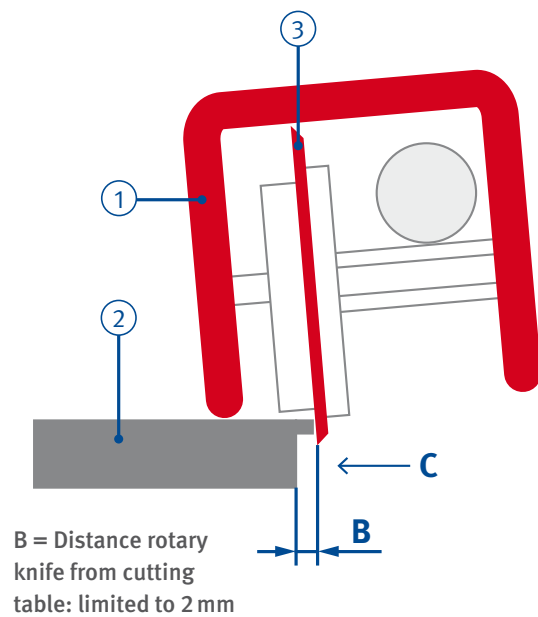

Fig. 14 Cutter Head

- In its lowest position, the knife edge of the rotary knife must be guarded by the cutting table, unless blunt rotary knives (Fig. 14, C) are used.

Paper dispensers

- The knife edge must fit closely to the paper or foil roll so that inadvertent contact is not possible.
- The paper or foil roll must be secured against falling out of its support.
- On movable dispensers, at least 2 castors must be lockable.

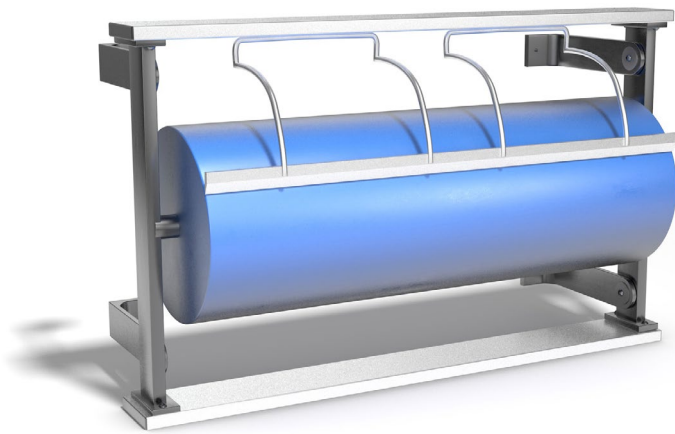

Fig. 15 Paper dispenser

Operating instructions

- The operating instructions must precisely describe the intended handling.
- If assembly is necessary for safe handling of the appliance, this must be described in the operating instructions.
- For rotary cutters and manual guillotine trimmers with blunt knives, the operating instructions may be given on the packaging.
- If guarding elements are not mounted at the time of sale, the operating instructions must include detailed assembly instructions and a warning that the machine must not be operated without the guarding system.
- Where knife holders are secured by force-fit friction, the operating instruction must indicate that the efficiency of friction elements must be checked regularly. A detailed description of the method of readjustment is also required.

3 Operation of hand-operated cutting devices

When operating hand-operated cutting devices, requirements from several state ordinances must be met. The following ordinances are of particular importance for the operation of a hand-operated cutting device:

- Workplace Ordinance (ArbStättV),
- Ordinance on Industrial Safety and Health (BetrSichV).

Information for employees

Employees working with hand-operated cutting devices must be appropriately informed and qualified to ensure safe use. This includes:

- Instruction manual: Instruction manuals serve to inform the operator how to use the device as intended. The instruction manual must be available in a suitable place in the company so that employees can obtain information quickly and reliably.
- Instruction: Employees must be instructed at least once a year. The instruction must be documented in writing. During the instruction, employees must be informed about existing hazards emanating from the work equipment, working materials and/or the working environment. In addition to the possible hazards, the instruction must also include existing protective measures and rules of conduct. Further information on the content, implementation and documentation of the instruction can be found on the BG ETEM website under the heading "Media".

- Operating instructions: The company must draw up operating instructions for the handling of hand-operated cutting devices and make them available to the employees. The operating instructions must provide information on:
 - Potential risks arising from hand-operated cutting devices.
 - Protective measures and rules of conduct.
 - First aid measures.

Instead of operating instructions, the employer may also provide user instructions or operating manuals supplied with the work equipment upon purchase if they contain information equivalent to operating instructions. The operating instructions shall be updated in the event of safety-relevant changes in the working conditions.

Inspection and maintenance

It must be ensured that the safety of the hand-operated cutting device is guaranteed over the entire period of use. This is to be achieved by regular inspections and maintenance. As part of the risk assessment, the employer must determine the intervals at which the hand-operated cutting device is to be inspected. When determining the inspection intervals, the information provided by the manufacturer, e.g. from the operating instructions, must be observed. In addition to the inspection intervals, the employer must also determine which qualifications the person must have in order to be allowed to carry out the inspection. If defects are detected, repair work is to be carried out immediately by the company or a third party. It must be ensured that the repair work is performed safely.

Annex

Directive 2001/95/EC of the European Parliament and of the Council of 3 December 2001 on general product safety (transposed by the German Product Safety Act)

THE EUROPEAN PARLIAMENT AND THE COUNCIL OF THE EUROPEAN UNION,

- Having regard to the Treaty establishing the European Community, and in particular Article 95 thereof,
- Having regard to the proposal from the Commission,
- Having regard to the opinion of the Economic and Social Committee,
- Acting in accordance with the procedure referred to in Article 251 of the Treaty, in the light of the joint text approved by the Conciliation Committee on 2 August 2001,

HAVE ADOPTED THE FOLLOWING DIRECTIVE:

CHAPTER I

Objective – Scope – Definitions

Article 1

- (1) The purpose of this Directive is to ensure that products placed on the market are safe.
- (2) This Directive shall apply to all the products defined in Article 2(a). Each of its provisions shall apply in so far as there are no specific provisions with the same objective in rules of Community law governing the safety of the products concerned.

Where products are subject to specific safety requirements imposed by Community legislation, this Directive shall apply only to the aspects and risks or categories of risks not covered by those requirements.

This means that:

- a) Articles 2(b) and (c), 3 and 4 shall not apply to those products insofar as concerns the risks or categories of risks covered by the specific legislation;
- b) Articles 5 to 18 shall apply except where there are specific provisions governing the aspects covered by the said Articles with the same objective.

Article 2

For the purposes of this Directive:

- a) “product” shall mean any product – including in the context of providing a service – which is intended for consumers or likely, under reasonably foreseeable conditions, to be used by consumers even if not intended for them, and is supplied or made available, whether for consideration or not, in the course of a commercial activity, and whether new, used or reconditioned.

This definition shall not apply to second-hand products supplied as antiques or as products to be repaired or reconditioned prior to being used, provided that the supplier clearly informs the person to whom he supplies the product to that effect;

- b) “safe product” shall mean any product which, under normal or reasonably foreseeable conditions of use including duration and, where applicable, putting into service, installation and maintenance requirements, does not present any risk or only the minimum risks compatible with the product’s use, considered to be acceptable and consistent with a high level of protection for the safety and health of persons, taking into account the following points in particular:
 - i) the characteristics of the product, including its composition, packaging, instructions for assembly and, where applicable, for installation and maintenance;
 - ii) the effect on other products, where it is reasonably foreseeable that it will be used with other products;
 - iii) the presentation of the product, the labelling, any warnings and instructions for its use and disposal and any other indication or information regarding the product;
 - iv) the categories of consumers at risk when using the product, in particular children and the elderly.

The feasibility of obtaining higher levels of safety or the availability of other products presenting a lesser degree of risk shall not constitute grounds for considering a product to be “dangerous”;

- c) “dangerous product” shall mean any product which does not meet the definition of “safe product” in (b);

- d) “serious risk” shall mean any serious risk, including those the effects of which are not immediate, requiring rapid intervention by the public authorities;
- e) “producer” shall mean:
 - i) the manufacturer of the product, when he is established in the Community, and any other person presenting himself as the manufacturer by affixing to the product his name, trade mark or other distinctive mark, or the person who reconditions the product;
 - ii) the manufacturer’s representative, when the manufacturer is not established in the Community or, if there is no representative established in the Community, the importer of the product;
 - iii) other professionals in the supply chain, insofar as their activities may affect the safety properties of a product;
- f) “distributor” shall mean any professional in the supply chain whose activity does not affect the safety properties of a product;
- g) “recall” shall mean any measure aimed at achieving the return of a dangerous product that has already been supplied or made available to consumers by the producer or distributor;
- h) “withdrawal” shall mean any measure aimed at preventing the distribution, display and offer of a product dangerous to the consumer.

CHAPTER II

General safety requirement, conformity assessment criteria and European standards

Article 3

- (1) Producers shall be obliged to place only safe products on the market.
- (2) A product shall be deemed safe, as far as the aspects covered by the relevant national legislation are concerned, when, in the absence of specific Community provisions governing the safety of the product in question, it conforms to the specific rules of national law of the Member State in whose territory the product is marketed, such rules being drawn up in conformity with the Treaty, and in particular Articles 28 and 30 thereof, and laying down the health and safety requirements which the product must satisfy in order to be marketed.

A product shall be presumed safe as far as the risks and risk categories covered by relevant national standards are concerned when it conforms to voluntary national standards transposing European standards, the references of which have been published by the Commission in the Official Journal of the European Communities in accordance with Article 4. The Member States shall publish the references of such national standards.
- (3) In circumstances other than those referred to in paragraph 2, the conformity of a product to the general safety requirement shall be assessed by taking into account the following elements in particular, where they exist:
 - a) voluntary national standards transposing relevant European standards other than those referred to in paragraph 2;
 - b) the standards drawn up in the Member State in which the product is marketed;
 - c) Commission recommendations setting guidelines on product safety assessment;
 - d) product safety codes of good practice in force in the sector concerned;
 - e) the state of the art and technology;
 - f) reasonable consumer expectations concerning safety.

- (4) Conformity of a product with the criteria designed to ensure the general safety requirement, in particular the provisions mentioned in paragraphs 2 or 3, shall not bar the competent authorities of the Member States from taking appropriate measures to impose restrictions on its being placed on the market or to require its withdrawal from the market or recall where there is evidence that, despite such conformity, it is dangerous.

Article 4

- (1) For the purposes of this Directive, the European standards referred to in the second subparagraph of Article 3(2) shall be drawn up as follows:
- a) the requirements intended to ensure that products which conform to these standards satisfy the general safety requirement shall be determined in accordance with the procedure laid down in Article 15(2);
 - b) on the basis of those requirements, the Commission shall, in accordance with Directive 98/34/EC of the European Parliament and of the Council of 22 June 1998 laying down a procedure for the provision of information in the field of technical standards and regulations and of rules on information society services (7) call on the European standardisation bodies to draw up standards which satisfy these requirements;
 - c) on the basis of those mandates, the European standardisation bodies shall adopt the standards in accordance with the principles contained in the general guidelines for cooperation between the Commission and those bodies;
 - d) the Commission shall report every three years to the European Parliament and the Council, within the framework of the report referred to in Article 19(2), on its programmes for setting the requirements and the mandates for standardisation provided for in subparagraphs a) and b) above. This report will, in particular, include an analysis of the decisions taken regarding requirements and mandates for standardisation referred to in subparagraphs a) and b) and regarding the standards referred to in subparagraph c). It will also include information on the products for which the Commission intends to set the requirements and the mandates in question, the product risks to

be considered and the results of any preparatory work launched in this area.

- (2) The Commission shall publish in the Official Journal of the European Communities the references of the European standards adopted in this way and drawn up in accordance with the requirements referred to in paragraph 1.

If a standard adopted by the European standardisation bodies before the entry into force of this Directive ensures compliance with the general safety requirement, the Commission shall decide to publish its references in the Official Journal of the European Communities.

If a standard does not ensure compliance with the general safety requirement, the Commission shall withdraw reference to the standard from publication in whole or in part.

In the cases referred to in the second and third subparagraphs, the Commission shall, on its own initiative or at the request of a Member State, decide in accordance with the procedure laid down in Article 15(2) whether the standard in question meets the general safety requirement.

The Commission shall decide to publish or withdraw after consulting the Committee established by Article 5 of Directive 98/34/EC. The Commission shall notify the Member States of its decision.

CHAPTER III

Other obligations of producers and obligations of distributors

Article 5

- (1) Within the limits of their respective activities, producers shall provide consumers with the relevant information to enable them to assess the risks inherent in a product throughout the normal or reasonably foreseeable period of its use, where such risks are not immediately obvious without adequate warnings, and to take precautions against those risks.

The presence of warnings does not exempt any person from compliance with the other requirements laid down in this Directive.

Within the limits of their respective activities, producers shall adopt measures commensurate with the characteristics of the products which they supply, enabling them to:

- a) be informed of risks which these products might pose;
- b) choose to take appropriate action including, if necessary to avoid these risks, withdrawal from the market, adequately and effectively warning consumers or recall from consumers.

The measures referred to in the third subparagraph shall include, for example:

- a) an indication, by means of the product or its packaging, of the identity and details of the producer and the product reference or, where applicable, the batch of products to which it belongs, except where not to give such indication is justified and
- b) in all cases where appropriate, the carrying out of sample testing of marketed products, investigating and, if necessary, keeping a register of complaints and keeping distributors informed of such monitoring.

Action such as that referred to in (b) of the third subparagraph shall be undertaken on a voluntary basis or at the request of the competent authorities in accordance with Article 8(1)(f). Recall shall take place as a last resort, where other measures would not suffice to prevent the risks involved, in instances where the producers consider it necessary or where they are obliged to do so further to a measure taken by the competent authority. It may be effected within the framework of codes of good practice on the matter in the Member State concerned, where such codes exist.

- (2) Distributors shall be required to act with due care to help to ensure compliance with the applicable safety requirements, in particular by not supplying products which they know or should have presumed, on the basis of the information in their possession and as professionals, do not comply with those requirements.

Moreover, within the limits of their respective activities, they shall participate in monitoring the safety of products placed on the market, especially by passing on information on product risks, keeping and providing the documentation necessary for tracing the origin of products, and cooperating in the action taken by producers and competent authorities to avoid the risks. Within the limits of their respective activities they shall take measures enabling them to cooperate efficiently.

- (3) Where producers and distributors know or ought to know, on the basis of the information in their possession and as professionals, that a product that they have placed on the market poses risks to the consumer that are incompatible with the general safety requirement, they shall immediately inform the competent authorities of the Member States thereof under the conditions laid down in Annex I, giving details, in particular, of action taken to prevent risk to the consumer.

The Commission shall, in accordance with the procedure referred to in Article 15(3), adapt the specific requirements relating to the obligation to provide information laid down in Annex I.

- (4) Producers and distributors shall, within the limits of their respective activities, cooperate with the competent authorities, at the request of the latter, on action taken to avoid the risks posed by products which they supply or have supplied. The procedures for such cooperation, including procedures for dialogue with the producers and distributors concerned on issues related to product safety, shall be established by the competent authorities.

CHAPTER IV

Specific obligations and powers of the Member States

Article 6

- (1) Member States shall ensure that producers and distributors comply with their obligations under this Directive in such a way that products placed on the market are safe.
- (2) Member States shall establish or nominate authorities competent to monitor the compliance of products with the general safety requirements and arrange for such authorities to have and use the necessary powers to take the appropriate measures incumbent upon them under this Directive.
- (3) Member States shall define the tasks, powers, organisation and cooperation arrangements of the competent authorities. They shall keep the Commission informed, and the Commission shall pass on such information to the other Member States.

Article 7

Member States shall lay down the rules on penalties applicable to infringements of the national provisions adopted pursuant to this Directive and shall take all measures necessary to ensure that they are implemented. The penalties provided for shall be effective, proportionate and dissuasive. Member States shall notify those provisions to the Commission by 15 January 2004 and shall also notify it, without delay, of any amendment affecting them.

Article 8

- (1) For the purposes of this Directive, and in particular of Article 6 thereof, the competent authorities of the Member States shall be entitled to take, inter alia, the measures in a) and in b) to f) below, where appropriate.
 - a) for any product:
 - i) to organise, even after its being placed on the market as being safe, appropriate checks on its safety properties, on an adequate scale, up to the final stage of use or consumption;
 - ii) to require all necessary information from the parties concerned;
 - iii) to take samples of products and subject them to safety checks;

- b) for any product that could pose risks in certain conditions:
- i) to require that it be marked with suitable, clearly worded and easily comprehensible warnings, in the official languages of the Member State in which the product is marketed, on the risks it may present;
 - ii) to make its marketing subject to prior conditions so as to make it safe;
- c) for any product that could pose risks for certain persons:
to order that they be given warning of the risk in good time and in an appropriate form, including the publication of special warnings;
- d) for any product that could be dangerous:
for the period needed for the various safety evaluations, checks and controls, temporarily to ban its supply, the offer to supply it or its display;
- e) for any dangerous product:
to ban its marketing and introduce the accompanying measures required to ensure the ban is complied with;
- f) for any dangerous product already on the market:
- i) to order or organise its actual and immediate withdrawal, and alert consumers to the risks it presents;
 - ii) to order or coordinate or, if appropriate, to organise together with producers and distributors its recall from consumers and its destruction in suitable conditions.
- (2) When the competent authorities of the Member States take measures such as those provided for in paragraph 1, in particular those referred to in d) to f), they shall act in accordance with the Treaty, and in particular Articles 28 and 30 thereof, in such a way as to implement the measures in a manner proportional to the seriousness of the risk, and taking due account of the precautionary principle.

In this context, they shall encourage and promote voluntary action by producers and distributors, in accordance with the obligations incumbent on them under this Directive, and in particular Chapter III thereof, including where applicable by the development of codes of good practice.

If necessary, they shall organise or order the measures provided for in paragraph 1 f) if the action

undertaken by the producers and distributors in fulfilment of their obligations is unsatisfactory or insufficient. Recall shall take place as a last resort. It may be effected within the framework of codes of good practice on the matter in the Member State concerned, where such codes exist.

- (3) In particular, the competent authorities shall have the power to take the necessary action to apply with due dispatch appropriate measures such as those mentioned in paragraph 1, b) to f), in the case of products posing a serious risk. These circumstances shall be determined by the Member States, assessing each individual case on its merits, taking into account the guidelines referred to in point 8 of Annex II.
- (4) (4) The measures to be taken by the competent authorities under this Article shall be addressed, as appropriate, to:
- a) the producer;
 - b) within the limits of their respective activities, distributors and in particular the party responsible for the first stage of distribution on the national market;
 - c) any other person, where necessary, with a view to cooperation in action taken to avoid risks arising from a product.

Article 9

- (1) In order to ensure effective market surveillance, aimed at guaranteeing a high level of consumer health and safety protection, which entails cooperation between their competent authorities, Member States shall ensure that approaches employing appropriate means and procedures are put in place, which may include in particular:
- a) establishment, periodical updating and implementation of sectoral surveillance programmes by categories of products or risks and the monitoring of surveillance activities, findings and results;
 - b) follow-up and updating of scientific and technical knowledge concerning the safety of products;
 - c) periodical review and assessment of the functioning of the control activities and their effectiveness and, if necessary, revision of the surveillance approach and organisation put in place.

- (2) Member States shall ensure that consumers and other interested parties are given an opportunity to submit complaints to the competent authorities on product safety and on surveillance and control activities and that these complaints are followed up as appropriate. Member States shall actively inform consumers and other interested parties of the procedures established to that end.

Article 10

- (1) The Commission shall promote and take part in the operation in a European network of the authorities of the Member States competent for product safety, in particular in the form of administrative cooperation.
- (2) This network operation shall develop in a coordinated manner with the other existing Community procedures, particularly RAPEX. Its objective shall be, in particular, to facilitate:
- a) the exchange of information on risk assessment, dangerous products, test methods and results, recent scientific developments as well as other aspects relevant for control activities;
 - b) the establishment and execution of joint surveillance and testing projects;
 - c) the exchange of expertise and best practices and cooperation in training activities;
 - d) improved cooperation at Community level with regard to the tracing, withdrawal and recall of dangerous products.

CHAPTER V

Exchanges of information and rapid intervention situations

Article 11

- (1) Where a Member State takes measures which restrict the placing on the market of products – or require their withdrawal or recall – such as those provided for in Article 8(1) b) to f), the Member State shall, to the extent that such notification is not required under Article 12 or any specific Community legislation, inform the Commission of the measures, specifying its reasons for adopting them. It shall also inform the Commission of any modification or lifting of such measures.

If the notifying Member State considers that the effects of the risk do not or cannot go beyond its territory, it shall notify the measures concerned insofar as they involve information likely to be of interest to Member States from the product safety standpoint, and in particular if they are in response to a new risk which has not yet been reported in other notifications.

In accordance with the procedure laid down in Article 15(3) of this Directive, the Commission shall, while ensuring the effectiveness and proper functioning of the system, adopt the guidelines referred to in point 8 of Annex II. These shall propose the content and standard form for the notifications provided for in this Article, and, in particular, shall provide precise criteria for determining the conditions for which notification is relevant for the purposes of the second subparagraph.

- (2) The Commission shall forward the notification to the other Member States, unless it concludes, after examination on the basis of the information contained in the notification, that the measure does not comply with Community law. In such a case, it shall immediately inform the Member State which initiated the action.

Article 12

- (1) Where a Member State adopts or decides to adopt, recommend or agree with producers and distributors, whether on a compulsory or voluntary basis, measures or actions to prevent, restrict or impose specific conditions on the possible marketing or use, within its own territory, of products by reason of a serious risk, it shall immediately notify the Commission thereof through RAPEX. It shall also inform the Commission without delay of modification or withdrawal of any such measure or action.

If the notifying Member State considers that the effects of the risk do not or cannot go beyond its territory, it shall follow the procedure laid down in Article 11, taking into account the relevant criteria proposed in the guidelines referred to in point 8 of Annex II.

Without prejudice to the first subparagraph, before deciding to adopt such measures or to take such action, Member States may pass on to the Commission any information in their possession regarding the existence of a serious risk.

In the case of a serious risk, they shall notify the Commission of the voluntary measures laid down in Article 5 of this Directive taken by producers and distributors.

- (2) On receiving such notifications, the Commission shall check whether they comply with this Article and with the requirements applicable to the functioning of RAPEX, and shall forward them to the other Member States, which, in turn, shall immediately inform the Commission of any measures adopted.
- (3) Detailed procedures for RAPEX are set out in Annex II. They shall be adapted by the Commission in accordance with the procedure referred to in Article 15(3).

- (4) Access to RAPEX shall be open to applicant countries, third countries or international organisations, within the framework of agreements between the Community and those countries or international organisations, according to arrangements defined in these agreements. Any such agreements shall be based on reciprocity and include provisions on confidentiality corresponding to those applicable in the Community.

Article 13

- (1) If the Commission becomes aware of a serious risk from certain products to the health and safety of consumers in various Member States, it may, after consulting the Member States, and, if scientific questions arise which fall within the competence of a Community Scientific Committee, the Scientific Committee competent to deal with the risk concerned, adopt a decision in the light of the result of those consultations, in accordance with the procedure laid down in Article 15(2), requiring Member States to take measures from among those listed in Article 8(1)(b) to (f) if, at one and the same time
- a) it emerges from prior consultations with the Member States that they differ significantly on the approach adopted or to be adopted to deal with the risk; and
 - b) the risk cannot be dealt with, in view of the nature of the safety issue posed by the product, in a manner compatible with the degree of urgency of the case, under other procedures laid down by the specific Community legislation applicable to the products concerned; and
 - c) the risk can be eliminated effectively only by adopting appropriate measures applicable at Community level, in order to ensure a consistent and high level of protection of the health and safety of consumers and the proper functioning of the internal market.
- (2) The decisions referred to in paragraph 1 shall be valid for a period not exceeding one year and may be confirmed, under the same procedure, for additional periods none of which shall exceed one year.

However, decisions concerning specific, individually identified products or batches of products shall be valid without a time limit.

- (3) Export from the Community of dangerous products which have been the subject of a decision referred to in paragraph 1 shall be prohibited unless the decision provides otherwise.
- (4) Member States shall take all necessary measures to implement the decisions referred to in paragraph 1 within less than 20 days, unless a different period is specified in those decisions.
- (5) The competent authorities responsible for carrying out the measures referred to in paragraph 1 shall, within one month, give the parties concerned an opportunity to submit their views and shall inform the Commission accordingly

CHAPTER VI

Committee procedures

Article 14

- (1) The measures necessary for the implementation of this Directive relating to the matters referred to below shall be adopted in accordance with the regulatory procedure provided for in Article 15(2):
 - a) the measures referred to in Article 4 concerning standards adopted by the European standardisation bodies;
 - b) the decisions referred to in Article 13 requiring Member States to take measures as listed in Article 8(1) b) to f).
- (2) The decisions referred to in paragraph 1 shall be valid for a period not exceeding one year and may be confirmed, under the same procedure, for additional periods none of which shall exceed one year.

Article 15

- (1) The Commission shall be assisted by a Committee.
- (2) Where reference is made to this paragraph, Articles 5 and 7 of Decision 1999/468/EC shall apply, having regard to the provisions of Article 8 thereof.

The period laid down in Article 5(6) of Decision 1999/468/ EC shall be set at 15 days.

- (3) Where reference is made to this paragraph, Articles 3 and 7 of Decision 1999/468/EC shall apply, having regard to the provisions of Article 8 thereof.
- (4) The Committee shall adopt its rules of procedure.

CHAPTER VII

Final provisions

Article 16

- (1) Information available to the authorities of the Member States or the Commission relating to risks to consumer health and safety posed by products shall in general be available to the public, in accordance with the requirements of transparency and without prejudice to the restrictions required for monitoring and investigation activities. In particular the public shall have access to information on product identification, the nature of the risk and the measures taken.

However, Member States and the Commission shall take the steps necessary to ensure that their officials and agents are required not to disclose information obtained for the purposes of this Directive which, by its nature, is covered by professional secrecy in duly justified cases, except for information relating to the safety properties of products which must be made public if circumstances so require, in order to protect the health and safety of consumers

- (2) Protection of professional secrecy shall not prevent the dissemination to the competent authorities of information relevant for ensuring the effectiveness of market monitoring and surveillance activities. The authorities receiving information covered by professional secrecy shall ensure its protection.

Article 17

This Directive shall be without prejudice to the application of Directive 85/374/EEC.

Article 18

- (1) Any measure adopted under this Directive and involving restrictions on the placing of a product on the market or requiring its withdrawal or recall must state the appropriate reasons on which it is based. It shall be notified as soon as possible to the party concerned and shall indicate the remedies available under the provisions in force in the Member State in question and the time limits applying to such remedies.

The parties concerned shall, whenever feasible, be given an opportunity to submit their views before the adoption of the measure. If this has not been done in advance because of the urgency of the measures to be taken, they shall be given such opportunity in due course after the measure has been implemented.

Measures requiring the withdrawal of a product or its recall shall take into consideration the need to encourage distributors, users and consumers to contribute to the implementation of such measures.

- (2) Member States shall ensure that any measure taken by the competent authorities involving restrictions on the placing of a product on the market or requiring its withdrawal or recall can be challenged before the competent courts.
- (3) Any decision taken by virtue of this Directive and involving restrictions on the placing of a product on the market or requiring its withdrawal or its recall shall be without prejudice to assessment of the liability of the party concerned, in the light of the national criminal law applying in the case in question.

Article 19

- (1) The Commission may bring before the Committee referred to in Article 15 any matter concerning the application of this Directive and particularly those relating to market monitoring and surveillance activities.
- (2) Every three years, following 15 January 2004, the Commission shall submit a report on the implementation of this Directive to the European Parliament and the Council.

The report shall in particular include information on the safety of consumer products, in particular on improved traceability of products, the functioning of market surveillance, standardisation work, the functioning of RAPEX and Community measures taken on the basis of Article 13. To this end the Commission shall conduct assessments of the relevant issues, in particular the approaches, systems and practices put in place in the Member States, in the light

of the requirements of this Directive and the other Community legislation relating to product safety. The Member States shall provide the Commission with all the necessary assistance and information for carrying out the assessments and preparing the reports.

Article 20

The Commission shall identify the needs, possibilities and priorities for Community action on the safety of services and submit to the European Parliament and the Council, before 1 January 2003, a report, accompanied by proposals on the subject as appropriate.

Article 21

- (1) Member States shall bring into force the laws, regulations and administrative provisions necessary in order to comply with this Directive with effect from 15 January 2004. They shall forthwith inform the Commission thereof.

When Member States adopt those measures, they shall contain a reference to this Directive or be accompanied by such reference on the occasion of their official publication. The methods of making such reference shall be laid down by Member States.

- (2) Member States shall communicate to the Commission the provisions of national law which they adopt in the field covered by this Directive.

Article 22

Directive 92/59/EEC is hereby repealed from 15 January 2004, without prejudice to the obligations of Member States concerning the deadlines for transposition and application of the said Directive as indicated in Annex III.

References to Directive 92/59/EEC shall be construed as references to this Directive and shall be read in accordance with the correlation table in Annex IV.

Article 23

This Directive shall enter into force on the day of its publication in the Official Journal of the European Communities.

Article 24

This Directive is addressed to the Member States.

Done at Brussels, 3 December 2001

For the European Parliament
The President
N. Fontaine

For the Council
The President
F. Vandembroucke

**Deutsche Gesetzliche
Unfallversicherung e.V. (DGUV)**

Glinkastraße 40
10117 Berlin, Germany
Telephone: +49 30 13001-0
Fax: +40 30 13001-9876
E-Mail: info@dguv.de
Internet: www.dguv.de