

Handling of thoriated
tungsten electrodes during tungsten
inert gas welding (TIG)

BGI 746

BG Information



BG

Vereinigung der Metall-
Berufsgenossenschaften

Thomas Ludwig
Dr. Vilia Elena Spiegel-Ciobanu

Translator: Annelie Beyer, Berufsgenossenschaft Metall Nord Süd

Handling of thoriated tungsten electrodes during tungsten inert gas welding (TIG)

Responsible for the contents:



BGM
Berufsgenossenschaft
Metall Nord Süd

CONTENTS

Foreword	3
1 Legal regulations and technical rules	4
1.1 BG Rule "Use of Work Equipment" (BGR 500), Part 2, Clause 2.26 "Welding, cutting and allied processes and BG Rule "Welding Fumes" (BGR 220)	4
1.2 Radiation Protection Ordinance	4
1.3 Ventilation measures according to BG Rule "Welding Fumes" (BGR 220), Clause 6.3	5
1.4 DIN EN 26848 "Tungsten electrodes for inert gas shielded arc welding"	6
2 Hazards	7
2.1 General hazards caused by radioactive substances, especially thorium	7
2.2 Hazard potential during welding with thoriated tungsten electrodes	7
2.3 Hazard potential during grinding of thoriated tungsten electrodes	8
2.4 Hazard potential for combined activities	8
2.5 Hazard potential during disposal of grinding dusts and electrode residues	8
2.6 Hazard potential during storage of thoriated tungsten electrodes	9
3 Exposure estimation	10
4. Protective measures	12
4.1 Use of non-thoriated tungsten electrodes	12
4.2 Use of thoriated tungsten electrodes	12
5 Explanations to radiation protection	14
Annex 1	17
Annex 2	18

Foreword

The present BG Information Sheet was updated with the support of the working group “Hazardous substances in welding and allied processes” within the expert committee “Metal and surface treatment” of the BG central office for safety and health (Berufsgenossenschaftliche Zentrale für Sicherheit und Gesundheit – BGZ) of the Head Office of the industrial Berufsgenossenschaften in cooperation with the technical department “radiation protection” of the Berufsgenossenschaft for precision mechanics and electrical engineering and is published by the association of the metal BGs in a new version.

The present BG information is primarily addressed to employers and is aimed at assisting them in the implementation of their duties arising from national occupational safety and health regulations, accident prevention regulations and possibly rules and show ways to avoid occupational accidents, diseases and health hazards.

It contains information on the safe handling of thoriated tungsten electrodes for tungsten inert gas welding and describes the necessary protective measures to be taken in order to exclude possible hazards during handling of these electrodes or to reduce them to a justifiable level.

The employer can assume that he reaches the protection aims required in the BG Rule “Use of Work equipment” (BGR 500), Part 2, Clause 2.26 “Welding, cutting and allied processes” and the BG Rule “Welding Fumes” (BGR 220), when observing the recommendations contained in the present BG information sheet, especially the exemplary possible solutions. This is also true for other than the solutions described here, provided they attain at least the same protection level. If technical rules have been established by relevant committees for the implementation of national occupational safety and health regulations, these shall be given priority:

NOTE. The accident prevention regulation “Welding, cutting and allied processes” (BGV D1) (version 2002) was withdrawn in the end of 2004. The contents of BGV D1 were transferred to the BG Rules “Welding Fumes” (BGR 220) and “Use of Work Equipment” (BGR 500)”, Part 2, Clause 26 “Welding, cutting and allied processes”. These BG Rules in combination with the GefStoffV (Hazardous Substances Ordinance) and StrlSchV. (Radiation Protection Ordinance) reflect the present state of legal regulations and technical rules, on which the whole concept of protective measures given in the present BGI is based.

The above information especially refers to clause 1 of the present BGI.

1 Legal regulations and technical rules

1.1 BG Rule “Use of Work Equipment” (BGR 500) Part 2, clause 2.26 “Welding, cutting and allied processes” and BG Rule “Welding Fumes” (BGR 220)

Clause 6.1 of BGR 220 “Selection of low emission processes and consumables” states:

“(6.1.1) The employer shall choose the welding, cutting and allied processes with the lowest possible emission of hazardous substances, taking account of the welding requirements to be met.”

“(6.1.5) During TIG welding with thoriated tungsten electrodes, the welding fume contains small portions of radioactive substances. These portions are much smaller during dc welding than during ac welding.”

Clause 6.2 of BGR 220 “Improvement of the working conditions” states:

“(6.2.2) The employer shall provide for working positions, in which the exposure of the employees to the generated hazardous substances is low.”

“(6.2.3) For compulsory technical reasons, clauses 6.1 and 6.2 may be deviated from.”

TIG welding with non-thoriated electrodes is a process in compliance with clause 6.1.1 of the above mentioned BGR 220. Thoriated tungsten electrodes may only be used for urgent technical reasons according to clause 6.2.3 of BGR 220. The specifications in the Radiation Protection Ordinance shall be observed in this context.

1.2 Radiation Protection Ordinance

The handling of radioactive substances is subject to the Radiation Protection Ordinance (Strahlenschutzverordnung, StrlSchV). The Radiation Protection Ordinance dated 1st August 2001 also contains regulations for the protection of employed persons and population for naturally occurring radioactive substances. In § 3 of the Radiation Protection Ordinance, the term “work activities” defines the handling of certain natural radioactive substances. In Annex XI certain “work activities” are explicitly listed, where significantly increased radiation exposure is possible. Among these are grinding of and d.c. welding with thoriated welding electrodes.

Principally, § 94 of the Radiation Protection Ordinance is valid. It requires that measures be taken in order to keep radiation exposure at the lowest possible level taking into account all circumstances of the individual case (minimising order).

If thoriated welding electrodes are ground or TIG welding with a.c. is carried out, the employer shall carry out a workplace related estimation of the body dose within six months after starting the activities (§ 95 para 1 Radiation Protection Ordinance). If the workplaces mentioned above are modified so that higher radiation exposure can occur, another estimation shall be carried out instantaneously. Assistance for the estimation is given in clause 3.

If the estimation required by § 95 para 1 Radiation Protection Ordinance reveals that the annual effective dose of 6 mSv may be exceeded, a report shall be made to the responsible authority for occupational safety and health according to national law. Then, the body dose shall not only be estimated but measured by appropriate methods within 9 months following radiation exposure (§ 95 para 2 Radiation Protection Ordinance).

A reliable statement on the radiation exposure, especially the possible incorporation of thorium, is only possible after a representative measurement of the activity concentration in the air at the workplace. A personal air sampling in the breathing zone is representative for the actual conditions at the workplace. With this procedure, an expensive analysis of the sampling filters is

necessary due to low sampling throughput.

In the case of a possible excess of the effective annual dose of 6 mSv, protective measures for a dose reduction shall be provided. The measuring results, the intended measures for a dose reduction, the actual type of work and the number of persons concerned shall be reported to the responsible authority.

The following applies to the **notifiable handling** of thoriated tungsten electrodes:

- As soon as a woman informs the employer that she is pregnant or breastfeeding, the working conditions shall be arranged in such a way that incorporation is excluded.

Note:

This does necessarily imply a prohibition of handling of thoriated tungsten electrodes as the requirement cannot be fulfilled otherwise.

- Persons are only allowed to continue notifiable work activities if they are subjected to a medical preventive examination like persons occupationally exposed to radiation within the respective calendar year.
- The following dose limit values for the effective dose per calendar year are valid:
 - 6 mSv for persons who are not occupationally exposed to radiation **during “work activities”**;
 - 20 mSv for persons occupationally exposed to radiation;
 - 400 mSv for the total occupational dose;
 - 6 mSv for persons under the age of 18.
- The results of the dose determinations shall be recorded and kept until the age of 75 of the person under surveillance (at least 30 years after termination of the relevant activity).
- The responsible authority may order further measures according to § 96 para 4 of the Radiation Protection Ordinance, among others appointment of a person responsible for radiation protection, preparation of an instruction on radiation protection, separation of radiation protection areas and requirements for waste disposal. In case of doubt, the responsible authority should always be contacted.
- If the notifiable “work activities” are carried out in foreign industrial premises, the persons concerned shall possess a radiation card registered with the responsible authority (§ 95 para 3 Radiation Protection Ordinance).

1.3 Ventilation measures according to BG Rule “Welding fumes” (BGR 220), clause 6.3

Independently from the selection of the welding processes, the employer shall take appropriate ventilation measures in compliance with the Hazardous Substances Ordinance taking account of processes, materials and conditions of use.

In clause 6.3 of BGR 220, ventilation measures for different processes and materials are listed, which generally result in sufficient compliance with the requirements of the Hazardous Substances Ordinance and the Radiation Protection Ordinance (figure 1-1).

Figure 1-1: Ventilation in rooms during processes with/without filler metal (excerpt from BGR 220)

Process	Filler or parent metal		Welding at coated steel
	Unalloyed and low alloy steel, aluminium materials	High alloy steel, non-ferrous materials (except for aluminium materials)	
TIG welding with non-thoriated tungsten electrodes	T	A/T	T
TIG welding with thoriated tungsten electrodes	A	A	A

T = technical (forced) ventilation
A = extraction at source of the hazardous substances

1.4 DIN EN 26848 “Tungsten electrodes for inert gas shielded arc welding”

In the standard, the different electrodes for TIG welding are specified. The table in figure 1-2 shows the standardised colour codes of the ignition electrodes:

Figure 1-2: Standardised colour codes of the ignition electrodes

Abbreviation	Oxide additive % (m/m)	Type of additive	Identification colour
WP	-	no additive	green
WT4	0,35 to 0,55	thorium dioxide ThO ₂	blue
WT10	0,80 to 1,20	thorium dioxide ThO ₂	yellow
WT20	1,70 to 2,20	thorium dioxide ThO ₂	red
WT30	2,80 to 3,20	thorium dioxide ThO ₂	violet
WT40	3,80 to 4,20	thorium dioxide ThO ₂	orange
WZ3	0,15 to 0,50	zirconium dioxide ZrO ₂	brown
WZ8	0,70 to 0,90	zirconium dioxide ZrO ₂	white
WL10	0,90 to 1,20	lanthanum oxide LaO ₂	black
WC20	1,80 to 2,20	cerium oxide CeO ₂	grey
Note: In the following list, other non-standardized colour codes are given			
Abbreviation	Oxide additive % (m/m)	Type of additive	Identification colour
WC10	0,90 to 1,20	cerium dioxide CeO ₂	pink
WL20 Witstar	1,80 to 2,20	lanthanum trioxide La ₂ O ₃	blue
WS2 Witstar	rare earths mixed doping	lanthanum trioxide La ₂ O ₃ yttrium trioxide Y ₂ O ₃	turquoise

2 Hazards

2.1 General hazards caused by radioactive substances, especially thorium

The special hazard arising during handling of radioactive substances is caused by the high energy radiation of these substances. The hazard potential especially depends on the

- **type of radiation exposure:**
internal or external
- **type of radiation**
alpha, beta, gamma radiation
- **type of handling.**

Thorium mainly emits alpha radiation; its decomposition products emit alpha and beta radiation. In addition, gamma radiation is emitted. The specific feature of alpha radiating substances is that

- after incorporation (inhalation or swallowing of fumes and dusts) its biological effect is significantly higher than with beta and gamma radiating substances,
- its reach is very short (few cm in air).

This special feature leads to different hazard potentials for different types of handling of thoriated tungsten electrodes. The use of thoriated tungsten electrodes therefore may lead to an internal radiation exposure (internal exposure) during welding and grinding due to inhalation of welding fumes or grinding dusts containing thorium.

On the other hand, storing of these electrodes for example leads to an external radiation exposure (external exposure). The inhalation of dusts or fumes leads to a significantly higher hazard potential (mainly caused by alpha radiation) than the storage of electrodes (through gamma and beta radiation).

Due to the fact that alpha radiation has a significantly shorter reach than gamma and beta radiation, it is not able to penetrate the outer skin layer and may be neglected in the assessment of external exposure.

The internal radiation exposure through inhalation of thorium containing dusts and fumes is especially harmful as the thorium entering the body in such a way preferably deposits in the bones. There, the alpha radiation may damage periosteum and marrow. The lung and the liver may also receive noteworthy radiation exposure after inhalation of thorium oxide. Other organs are only affected to a significantly lesser extent.

As compared to the hazard caused by inhalation the hazard caused by swallowing of dusts containing thorium oxide may be neglected due to the low solubility of thorium oxide.

2.2 Hazard potential during welding with thoriated tungsten electrodes

During TIG welding with thoriated tungsten electrodes, fumes containing tungsten oxide are generated. Inhalation of these fumes may cause internal radiation exposure. The limit value for the effective dose¹ **for non occupationally exposed persons during "activities"** (i.e. also

¹ The limit value of the annual activity supply (Grenzwert der Jahresaktivitätszufuhr (GJAZ)) was

during handling of thoriated TIG electrodes) of 6 mSv per year is a measure for the hazard evaluation.

Investigations yielded the following results:

- It can be assumed that during TIG welding with direct current the above annual limit value (6 mSv) is not exceeded by inhalation of thorium oxide.
- During TIG welding with alternating current, e.g. with aluminium materials, exposure occurs which can no longer be neglected. Here, the above annual limit value (6 mSv) may be exceeded by inhalation of thorium oxide.
- The external radiation exposure by the gamma component during welding may be neglected. The maximum doses due to external radiation are far below the natural radiation exposure.
- An unfavourable welding position (breathing zone of the welder in the ascending welding fume column) affects the inhalative exposure (significant increase of exposure).

2.3 Hazard potential during grinding of thoriated tungsten electrodes

During grinding of thoriated tungsten electrodes radioactive dust is released, which gives rise to the hazard of an internal radiation exposure by inhalation.

Investigations yielded the following results:

- During grinding of thoriated tungsten electrodes exposures arise, which can no longer be neglected. Here as well the above annual limit value (6 mSv) may be exceeded by inhalation of thorium oxide.
- The external radiation exposure by the gamma component and by the beta radiation may be neglected for grinding under normal working conditions. The maximum doses due to external radiation are far below the natural radiation exposure.

2.4 Hazard potential for combined activities

For combined activities (welding and grinding) the relevant exposures sum up, which leads to a higher probability of exceeding the above annual limit value (6mSv).

2.5 Hazard potential during disposal of grinding dusts and electrode residues

During disposal of grinding dusts, especially during cleaning of collectors of extraction systems, higher amounts of dusts containing thorium oxide may be dispersed and inhaled. The resulting incorporation may exceed the exposure during grinding or welding by orders of magnitude. The disposal of the electrode residues does not present a hazard.

2.6 Hazard potential during storage of thoriated tungsten electrodes

The external radiation exposure by gamma and beta radiation during storage may be neglected for a small quantity stored (some packages of electrodes). For larger quantities it may, however, be useful for a dose minimisation to install protective measures in the form of suitable shielding.

3. Exposure estimation

The time duration of the activities, i.e. the frequency of grinding the electrodes or the number of hours per year thoriated electrodes are used for welding, is an important factor for the radiation exposure. For estimation, the table in figure 3-1 lists the maximum values of the BG measuring program. These values are effective dose values, calculated from the activity determinations in the welder's breathing air taking into account all relevant nuclides. For the calculation, the dose factors from the Bundesanzeiger G 1990 No. 160 a were considered.

The exposure during welding is a **time weighted average concentration** containing setting periods, therefore it does **not** represent the pure arcing time. With these data the required estimation of the annual exposure can be carried out on the basis of the annual working time of the welder and the number of grinding activities per year. The decisive factor is, if an annual dose of 6 mSv is exceeded.

When the above dose is exceeded, further measures are required (see clause 2.1). The data in the table in figure 3-1 refer to work places without local capture/exhaust.

An effective capture in combination with a local exhaust may reduce the exposure by the factor 2². This may be used for the estimation.

Example 1

A welder works for 250 hours per year with the d.c. process and for 1500 hours per year with the a.c. process with WT40 electrodes (setting periods included). On average, he grinds these electrodes about 3000 times a year.

The possible annual exposure is calculated as follows:

$$250h \times 0,12 \mu\text{Sv/h} + 1500 h \times 8,4 \mu\text{Sv/h} + 3000 \times 0,58 \mu\text{Sv}$$

= 14 370 μSv or about 14,4 mSv per year

Figure 3-1: Maximum values of the BG measuring program

Activities	with WT20 electrodes	with WT40 electrodes
a.c. welding	4,2 $\mu\text{Sv/h}$	8,4 $\mu\text{Sv/h}$
d.c. welding	0,06 $\mu\text{Sv/h}$	0,12 $\mu\text{Sv/h}$
grinding	0,29 $\mu\text{Sv/h}$	0,58 $\mu\text{Sv/grinding process}$

Example 2

A welder exclusively works with the d.c. process for 1760 hours per year, half of his working hours with WT20, the other half with WT40 electrodes. He grinds the electrodes about 1000 times a year.

The annual exposure is calculated as follows:

$$880 h \times 4,2 \mu\text{Sv/h} + 880 h \times 8,4 \mu\text{Sv/h} + 500 \times 0,58 \mu\text{Sv} + 500 \times 0,29 \mu\text{Sv}$$

= 11 523 μSv or about 11,5 mSv per year.

² This factor is based on an analysis of measuring data from welding and allied processes (proposal of the expert committee see annex 2 No. 5)

Example 3

A welder always uses WT30 electrodes for the a.c. process. His annual working hours during welding (setting periods included) are 1200 h. He not only grinds for himself, however, but also for his numerous colleagues. This results in 5000 grinding processes per year. The content of thorium in the WT30 electrode is exactly between the thorium contents in the WT20 and the WT40, therefore it is appropriate to take the mean value of the values given in the table in figure 3-1 on page 10 for these electrodes.

The possible annual exposure is calculated as follows:

$$1200 \text{ h} \times 6,3 \mu\text{Sv/h} + 5000 \times 0,44 \mu\text{Sv}$$

= 9 760 μSv or about 9,8 mSv per year

4 Protective measures

For compliance with the Hazardous Substances Ordinance, the BG Rule “Use of Work Equipment” (BGR 500) Part 2, Clause 2.26 “Welding, cutting and allied processes” and the BG Rule “Welding Fumes” (BGR 220) the following protective measures may be used:

4.1 Use of non-thoriated tungsten electrodes

As far as possible, non-thoriated tungsten electrodes shall be used.

Non-thoriated tungsten electrodes with other oxide additives as e.g. cerium or lanthanum containing electrodes are available and standardised in DIN EN 26848. For the use of non-thoriated tungsten electrodes no other protective measures are necessary on the basis of the Radiation Protection Ordinance.

4.2 Use of thoriated tungsten electrodes

- If the use of thoriated tungsten electrodes cannot be dispensed with for urgent technical reasons, effective capture is necessary in combination with an extraction device at the source of generation both for grinding them and for welding (see figure 1-1 on page 6).

The extraction shall in addition comply with the requirements for the separation of carcinogenic substances.

During welding, appropriate welding fume extraction devices shall be used, e.g. stationary devices with filter of category K* or mobile devices tested by BGIA.

During grinding, the extraction shall comply with the requirements for dust extractors of class K* according to the test criteria for dust removing machines.

The effectiveness of extractors shall be verified during welding with alternating current by measurement of the inhalable fraction according to DIN EN 481 at the person in the breathing zone.

- According to clause 6.2.2 of BGR 220, the body posture of the welder both for welding and grinding should be so that the hazardous substances released are kept away from the breathing zone as far as possible.
- Regular removal and disposal of the deposited dust from thoriated tungsten electrodes in a safe way, i.e. without skin contact, by avoidance of dust raising and inhalation.
- Prohibition of eating, drinking and smoking at the workplace in combination with a consistent execution of work hygiene measures, e.g. washing of hands.
- An exposure estimation shall be carried out according to § 95 para 1 of the Radiation Protection Ordinance.
- If the estimation according to § 95 para 1 of the Radiation Protection Ordinance shows an effective annual dose of more than 6 mSv, the exposure shall be determined by personal measurements.

* K for carcinogenic substances

In this case, a notification to the responsible authority is required (body responsible for occupational safety and health according to national legislation, e.g. the labour inspectorates, the federal inspectorates for occupational safety and health).

- For the storage of thoriated tungsten electrodes additional protective measures may be necessary, which also take account of external radiation exposure.

5 Explanations to radiation protection

In the following, radiation protection terms used in this BG Information Sheet are explained in a simplified way. Some of these terms are explained in more detail in § 3 of the Radiation Protection Ordinance.

- **Activity**

The activity is a measure for the radiation potential of a substance. It describes how many radioactive decays occur per unit of time. The unit is the Becquerel (Bq). Until recently, limit values for the annual intake of activity into the human body existed. These limit values of the annual activity supply (Grenzwerte der Jahresaktivitätszufuhr, GJAZ) have been dispensed with by the amendment of the Radiation Protection Ordinance dated 1st August 2001. By now, the basis is the primary limit value of the effective dose.

- **Activity concentration**

Concentration of a radioactive substance. e.g. in air. The activity is measured in a specified volume. The unit is Bq/m³. If the standard breathing rate of a human being is assumed to be 1,2 m³/h, it is e.g. possible to calculate the effective dose resulting from a possible incorporation by multiplication with the activity concentration and the corresponding dose factor.

- **Alpha radiation**

The alpha radiation is a kind of ionising radiation. Alpha particles with high energy content, i.e. helium cores, are ejected from the atomic nuclei of a radioactive substance. Alpha radiation has a very short reach.

- **"Work activities"** (in the sense of the Radiation Protection Ordinance)

Activities, which may increase the radiation exposure as compared to naturally existing radioactivity (for a more detailed definition see § 3 para 1 No. 2 of the Radiation Protection Ordinance).

- **Becquerel (Bq)**

The Bq is the unit for the activity. One Bq means one radioactive decay per second.

- **Persons occupationally exposed to radiation**

Persons, who may be exposed to an effective annual dose of more than 6 mSv at work during "activities" in the sense of the Radiation Protection Ordinance.

Note:

During handling of artificial radioactive substances, a value of 1 mSv is valid instead of 6 mSv.

- **Beta radiation**

Beta radiation is a type of ionising radiation.

Beta particles with high energy content – electrons or positrons – are ejected from the atomic nuclei of a radioactive substance.

- **Dose factor**

Conversion factor which enables a conversion from the activity intake into the human body to a dose. The dose factor depends on the nuclide, the incorporation path (inhalation, swallowing), on the age of the person concerned and on the chemical form of the incorporated nuclide.

- **Effective dose**

This quantity reflects the effect of the radiation exposure on the whole person taking into account the different radiation sensitivity of different organs. The unity is the Sievert.

- **Gamma radiation**

The short-wave electromagnetic radiation with high energy content emitted by atomic nuclei of radioactive substances. This radiation has a high penetration potential.

- **Body dose**

This is a collective term for the radiation dose for the whole body or for individual organs of a person.

- **Incorporation**

Incorporation is the intake of radioactive substances into the human body. This may happen in the form of inhalation, swallowing, intake via the skin or penetration through wounds of radioactive substances.

- **Ionising radiation**

Radiation with high energy content, which is e.g. emitted by radioactive substances or from x-ray equipment and which can ionise the atoms or molecules it hits, i.e. charge them electrically and thus change their chemical properties.

- **Nuclide**

Designation of a specific type of atom. There are about 2 500 different nuclides, 2 200 of them being radioactive (radio nuclides). For thorium contained in tungsten electrodes, the three nuclides Th-228, Th-230 and Th-232 have to be considered.

- **Radioactivity**

This is the property of many substances to transform themselves by emitting ionising radiation.

- **Sievert (Sv), Millisievert (mSv) and Microsievert (µSv)**

The unity of the radiation dose (Sv) takes the different biological effectiveness of different radiation types on humans into account.

The following relations apply: $1000 \mu\text{Sv} = 1 \text{ mSv}$ and $1000 \text{ mSv} = 1 \text{ Sv}$

- **Radiation exposure**

Action of radiation on humans. The "quantity" of the radiation exposure is called "dose". There is a distinction between internal and external radiation exposures.

- **Radiation exposure, internal**

If radioactive substances get access into the human body, they radiate the person or his/her organs and tissues from the inside. The resulting radiation exposure is called internal radiation exposure.

- **Radiation exposure, external**

If a radiation source (radioactive substance, x-ray equipment) acts on the human being only from the outside, this is referred to as external radiation exposure.

Annex 1

Principal sketch "Tungsten inert gas welding (TIG)

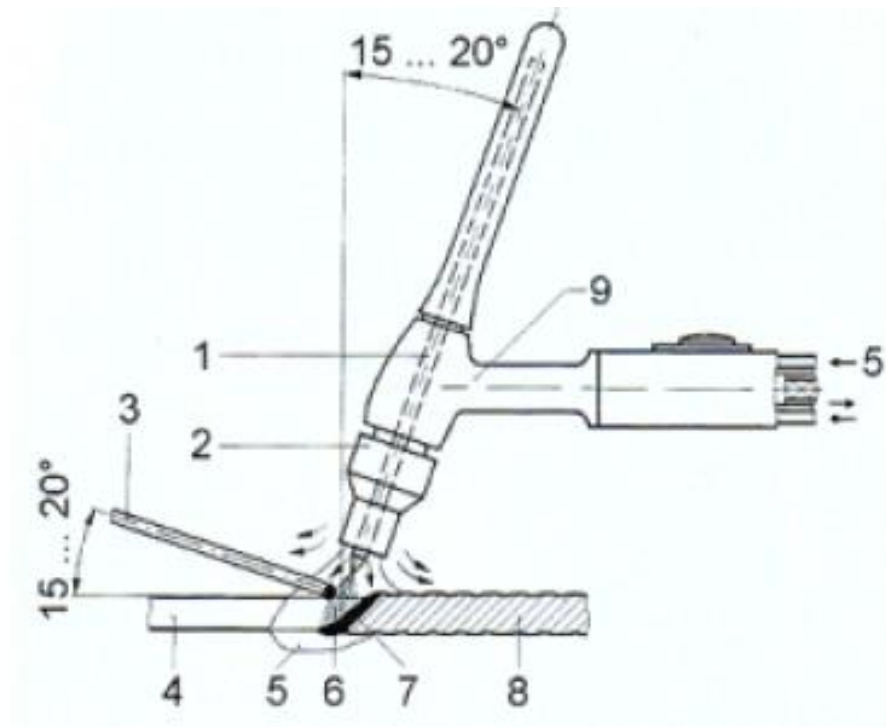

1 tungsten electrode
2 shielding gas nozzle
3 filler metal

4 workpiece
5 shielding gas
6 arc

7 melting bath
8 weld metal
9 torch

Annex 2

Regulations and Rules

In the following, the regulations and rules which shall primarily be observed are listed; see as well last paragraph but one of the Foreword:

1 Laws/ordinances

- Strahlenschutzverordnung (StrlSchV)
- Bekanntmachung der Dosisfaktoren; Bundesanzeiger G 1990; Jhrg. 53; Nummer 160a; dated 28 August 2001

Source of supply: bookselling trade or Carl Heymanns Verlag KG, Luxemburger Straße 449, 50939 Köln

2 BG Rules, Regulations and Information Sheets for occupational safety and safety

- “Welding fumes” (BGR 220)
- “Use of work equipment” (BGR 500)

Source of supply: Responsible BG or Carl Heymanns Verlag KG, Luxemburger Straße 449, 50939 Köln

3 Standards

- DIN EN 26 848
Tungsten electrodes for inert gas shielded arc welding and for plasma cutting and welding

Source of supply: Beuth-Verlag, Burggrafenstraße 6, 10787 Berlin

4 Handbuch des berufsgenossenschaftlichen Instituts für Arbeitssicherheit – BIA, (BIA handbook) No. 510210, DIN EN 335-2-69 Annex 1

Source of supply: Berufsgenossenschaftliches Institut für Arbeitsschutz der Deutschen Gesetzlichen Unfallversicherung (BGIA)
Alte Heerstraße 111, 53754 Sankt Augustin

5 Other publications

- T. Ludwig, D. Schwaß, G. Seitz, H. Siekmann;
Intakes of Thorium while using thoriated Tungsten electrodes for TIG welding;
Health Physics 77: 462-469; 1999.

Source of supply: Berufsgenossenschaft der Feinmechanik und Elektrotechnik,
Fachbereich Strahlenschutz, Gustav-Heinemann-Ufer 130, 50968 Köln

- Ludwig, Schwaß, Seitz, Siekmann, Spiegel-Ciobanu;
Freisetzung radioaktiver Stoffe beim WIG-Schweißen mit thoriumhaltigen Elektroden;
Die BG; Ausgabe Januar 1997.

Source of supply: Erich Schmidt Verlag GmbH & Co., Genthiner Str. 30 G, 10785 Berlin

- Vorschlag des Fachausschusses "Metall- und Oberflächenbehandlung",
"Sachgebiet Schadstoffe in der Schweißtechnik"
für die Festlegung eines Luftgrenzwertes für Schweißrauche,
Anlage 1 "Auswertung von Messdaten aus der Schweißtechnik", WIG Schweißen

Source of supply: Berufsgenossenschaft Metall Nord Süd, Fachausschuss
"Metall und Oberflächenbehandlung", Seligmannallee 4, 30173 Hannover